

CONDENS SAFE™

NEUTRALIZER CS2

AN INNOVATION IN THE CONDENSATE NEUTRALIZER DOMAIN

The unit is compact and easy to install with the wall brackets included. Engineered media is contained in a bag that can be replaced without having to disconnect the unit.



TIME INDICATOR

It is important to change your media bags every year in order to protect the environment and the components of the building. That's why we've included a 12-month time indicator so the user knows exactly when to replace it.

No messy media replacement

Wall supports included

Environment friendly

CONDENS SAFE NEUTRALIZER

MODEL #CS2

ADVANTAGES

- ▶ Brackets are included to fix the unit to the wall
- ▶ Engineered media is contained in a replaceable bag
- ▶ No disconnection required to replace media
- ▶ Time indicator (12 months) included
- ▶ No by-pass needed
- ▶ Economical and environment friendly
- ▶ Can be connected to hard piped
- ▶ Long-life heavy duty tank and cover

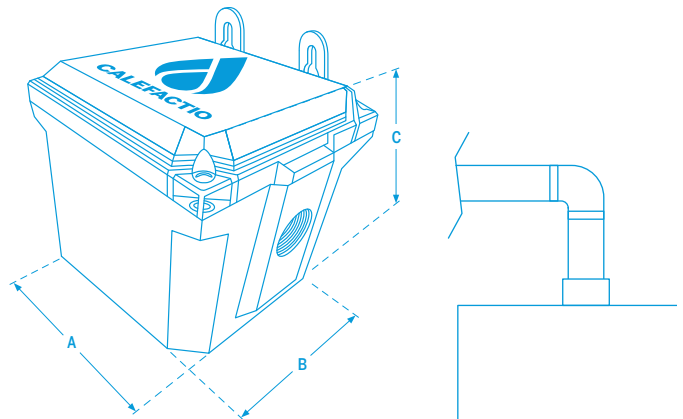

A		B		C		Inlet/Outlet	Treatment capacity				Max. treatment volume*
in	cm	in	cm	in	cm		MBH	kWh	gal/h	L/h	
5¾	14.5	4¾	12	5	13	¾" FNPT	525	154	2.1	8	2.1 GPH (8 LPH)

* Verify condensate flowrate on your appliance. In general, 500,000 BTU/hr at 92% efficiency should generate around 1.6 gal/hr.

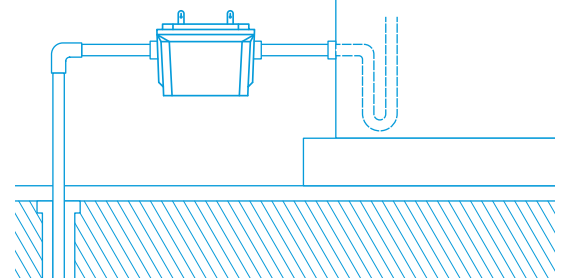
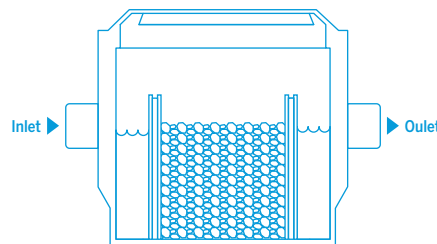

Included



One media bag
(#CSM2)



12-month time indicator



One ¾" straight fitting



One 90° elbow

Quebec, Canada
T 450 951.0818
F 450 951.2165

[calefactio_solutions](#)
[calefactio](#)
[calefactio-solutions-inc](#)

[calefactio.com](#)

