



Model 801 Thermostatic Water Controller High-Low Water Mixer Unit No. 72999

CAPACITIES – MODEL 801

Pressure Drop PSI	5	10	20	30	45	60	80
Valve Number	Capacity						
801-GPM	17	25	34	40	50	57	65
801-LPM	64	94	128	151	189	210	246

1/2 gpm when properly installed in recirculated system.

Master water mixing valve shall be of the thermostatic type with liquid-filled thermal motor. It shall have lead free brass body construction with replaceable corrosion-resistant components. Valve construction shall employ a sliding piston control mechanism. Sliding piston and liner shall be of stainless steel material. Valve shall come equipped with union end stop and check inlets with removable stainless steel strainers. Valve shall control temperature from a low flow of 1 GPM* up to a maximum flow rate for a given pressure differential. Valve shall provide protection against hot or cold supply line failure and thermostat failure.

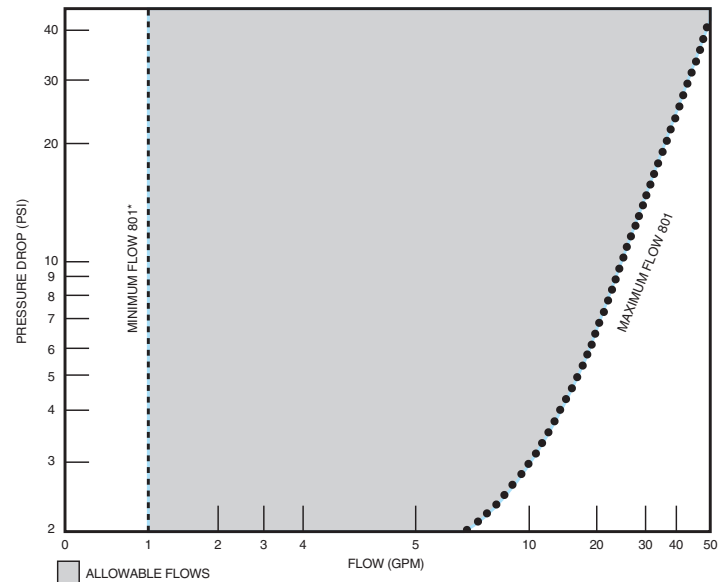

- FINISH:** Brass
 Rough Chrome
 Other

- | TEMP. RANGE | SET POINT | |
|---------------|-----------|--------------------------|
| 70° to 100°F | 80°F | <input type="checkbox"/> |
| 90° to 120°F | 110°F | <input type="checkbox"/> |
| 110° to 140°F | 130°F | <input type="checkbox"/> |
| Special _____ | _____ | <input type="checkbox"/> |

- Optional Test Connection**
 Including garden hose connection, shut-off and thermometer.
- Brass
 Rough Chrome

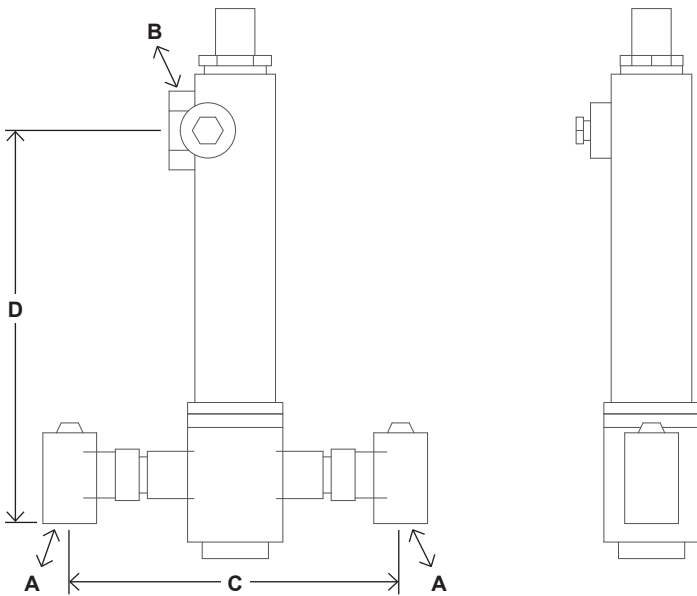

DIMENSIONS

Valve Number	A	N.P.T.	B	N.P.T.	C	D
801		3/4"		1"	10"	12"

Dimensions are for reference purposes only. For rough-in dimensions please refer to Lawler's Revit/BIM models found at temperedwater.com.

**Model 801
Unit No. 72999**

Typical Installation

Install the mixing valve below the hot water tank or heater. If this is not possible, pipe in a heat trap as shown in Figure 1 with an approximate 2' drop.

Connect a tempered water return line as shown in Figure 1. This allows flow through both ports of the mixing valve during periods of no draw.

If a dual temperature system is used, a separate recirculating loop and pump are required to return high temperature hot water to the water heater. See Figure 2.

Install an aquastat at the tempered water return pump.

Install the water heater per manufacturer's instructions.

Figure 1

When used in a single temperature recirculating system

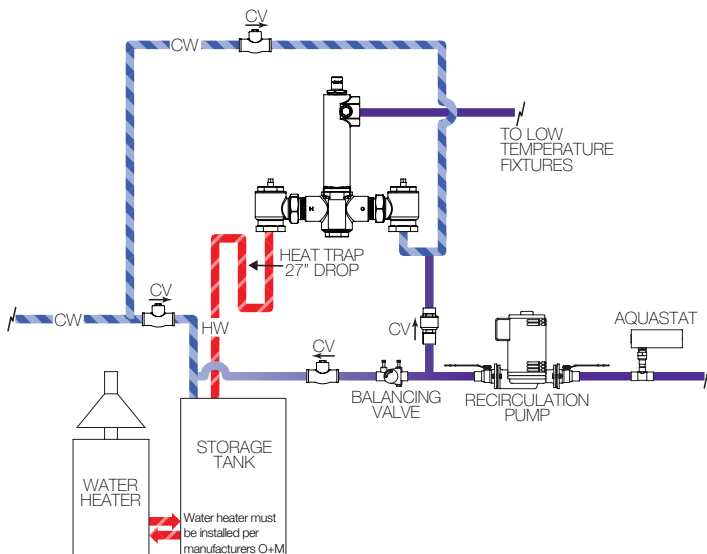

Figure 2

When used in a dual temperature recirculating system

