

BRADFORD WHITE

BRUTE FT[®]

Floor Standing Boiler or Combination Boiler and Water Heater

Stainless Steel Fire-Tube Design

95% AFUE

Full 10:1 Modulation

*First minute delivery at a 70° degree
rise at 6+gpm (22.7 lpm)*

*Continuous delivery at a 70° degree
rise at 5.2 gpm (19.7 lpm)*

*Exclusive Shell and Coil Domestic
Hot Water Heat Exchanger*

10 Year Heat Exchanger Warranty

***Industry's First Floor Standing Combi
Boiler providing Heating and Domestic
Hot Water Simultaneously***



Exceptional Residential Heating
and Hot Water to Meet the
Demands of any Household

BRADFORD WHITE[®]
WATER HEATERS
Built to be the Best[™]

The Brute FT® Floor Standing Combi Series

Heat and Hot Water in One Space-Saving Package.

Bradford White provides simple, reliable solutions to heating and hot water needs. Designed with the homeowner and installer in mind, The Brute FT® Floor Standing Combi Boiler is the best option for any new or replacement application.



Top water, gas, and venting connections ensure ease of install while saving space that competitive boilers cannot.

The Brute FT® Floor Standing Combi Boiler is the first unit of its kind to provide heating and domestic hot water simultaneously.

Protective features including a mechanical mixing valve guarantee silent and accurate operation. Innovative Shell and Coil DHW Heat Exchanger design supplies instantaneous hot water quicker than the competition, while protecting the life expectancy of the boiler.

All Brute FT® Floor Standing Combi Boilers are backed by Bradford White's stress-free 10-Year Heat Exchanger Warranty.

The Brute FT® Floor Standing performs at an ultra-high efficiency of up to 95% AFUE (Annual Fuel Utilization Efficiency) and is ENERGY STAR®

Brute FT® Series Domestic Hot Water Advantage

The Brute FT® Floor Standing Combi Boiler's unique, integrated domestic hot water mini-indirect tank delivers stable hot water on demand. This design eliminates the "cold water sandwich" problem experienced with brands utilizing flat plate designs.

- Provides immediate response to demand
- Hot boiler water inside the tank provides immediate recovery
- Heated in a coiled, corrugated stainless tube contained in a heavily-insulated stainless tank
- Inside the tank, boiler water surrounds the domestic hot water coil keeping it hot at all times
- Contains approximately one gallon of storage

The Brute FT® Floor Standing Combi Boiler easily and efficiently meets the space heating and hot water needs of today's modern homes.



The Brute FT[®] Floor Standing Combi Series

Proven Innovation.

- Full modulation burner with full 10:1 turn down ratio matches heating loads to provide efficient and quiet response
- Durable, stainless steel fire tube heat exchanger offers longer life expectancy and superior heating performance
- All piping connections on top for easy installation
- Simple dial and set control functions
 - Built-in low loss header (no primary/secondary piping required)
 - Small, space-saving footprint
 - First combi boiler with dedicated recirculation
- Internal 120 power receptacle simplifies condensate pump installation, built in 24v transformer powers additional limits
- Easy front access - No screws, securely hinged cabinet
- 3 removable side access panels
- Anti scald mixing valve included with each combi boiler
- Leveling legs adjust for stability on uneven surfaces
- Integrated handles on sides of the cabinet for boiler placement
- First external intake air filter

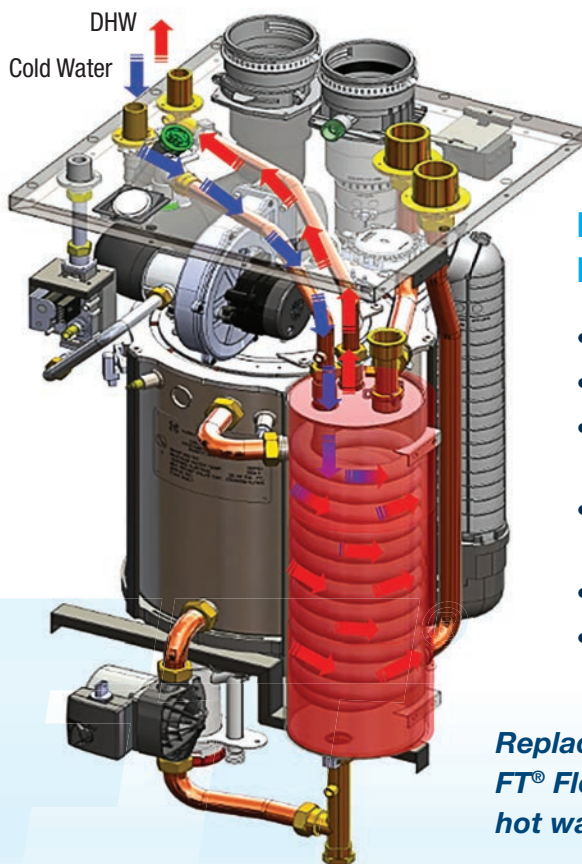

Brute FT[®] Series Shell & Coil DHW Heat Exchanger Technology

- First minute delivery at a 70° degree rise at 6+gpm (22.7 lpm)
- Continuous delivery at a 70° degree rise at 5.2 gpm (19.7 lpm)
- One gallon of stored hot water provides immediate hot water on demand
- First combi floor standing boiler to provide space heating and DHW simultaneously
- 40+ feet of stainless steel coil provide superior DHW performance
- Supplied (ASSE1070) mechanical mixing valve provides silent and reliable domestic hot water tempering

Replace your old boiler and water heater system with a Brute FT[®] Floor Standing Combi Boiler to satisfy your heating and hot water needs in a small, space-saving footprint.

The Brute FT® Floor Standing

Specification	Units/Condition	Combi Boilers		Heating Only Boilers	
		BFTCF199		BFTHF199	
Input, Max Fire	MBH (kW)	199 (58)			
AHRI Cert. Heating Capacity	MBH (kW)	000 (00)		000 (00)	
Weight, Unit	lbs. (kg)	000 (00)		130 (58.9)	
H x W x D	Inches (cm)	30.4 x 17.9 x 19.6 (77.2 x 45.5 x 49.8)			
Turndown	–	10:1			
Heating “CH” Supply	NPT	1 1/2"			
Heating “CH” Return	NPT	1 1/2"			
DHW Outlet	NPT	3/4"		—	
DHW Inlet	NPT	3/4"		—	
DHW Flow Rate	35°F Rise - GPM (l/m)	9.9 (38)		—	
	45°F Rise - GPM (l/m)	7.7 (30)		—	
	70°F Rise - GPM (l/m)	5.28 (20)		—	
	77°F Rise - GPM (l/m)	4.8 (18)		—	
Minimum Flow Rate	GPM (l/m)	0.5 (1.9)		—	
Gas Inlet	NPT	3/4"			
Certified Efficiency	AFUE	95%			
Condensate Line	NPT	1/2"			
Gas Supply Pressure	In WC	3.5 - 10.5" w.c. Natural Gas, 8-13" w.c. Propane			
Pressure Relief Settings	psi (kPa)	30 (307)			
Air Intake Collar	Inches (cm)	3 (7.6)			
Exhaust Outlet Collar	Inches (cm)	3 (7.6)			
Vent Diameter & Equivalent Length	Inches/ft. (mm/m)	2/50 (51/15.2) 3/100 (76/30.5)			
Vent Material	–	PVC, CPVC, Stainless Steel, Polypropylene			
Fuel	–	Natural Gas or Propane (Propane conversion kit included)			
Power Supply	Volts/Hertz	120/60			
Warranty	–	Limited 10 year heat exchanger / 5 year parts			

(Metric)



Dimensions and specifications subject to change without notice in accordance with our policy of continuous product improvement.

INCLUDED WITH BRUTE FT® FLOOR STANDING SERIES

Boiler Circulator (Installed)	3 in 1 Brass Accessory Adapter	Automatic Air Elimination Vent	Pressure Relief Valve	Propane Conversion Kit	Anti-scald Mixing Valve	Air Intake Filter (Installed)	Outdoor Sensor

OPTIONAL INSTALLATION ACCESSORIES

DHW Recirculation Sensor (Combi Only)	Condensate Neutralizer/Pump P/N FT3007	Concentric Stainless Steel Adapter Ki P/N FT3006	Concentric Polypropylene Adaptor Kit P/N FT3002	Vent Terminal – Flush 2" (51mm) P/N CA010100 3" (76mm) P/N CA010101	Vent Terminal – Bazooka 2" (51mm) P/N 239-44069-02 3" (76mm) P/N 239-44069-01

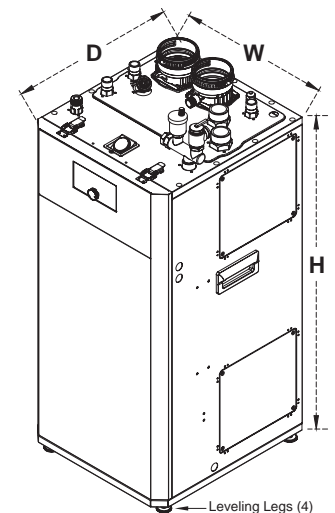

Built to be the Best®



For field service, contact your professional installer or local Bradford White sales representative.

Sales 800-523-2931 • Fax 215-641-1612

Technical Support 800-334-3393 • Email techserv@bradfordwhite.com

Warranty 800-531-2111 • Email warranty@bradfordwhite.com

International: Telephone 1-215-641-9400

Email international@bradfordwhite.com / www.bradfordwhite.com